

In the circuit shown, it is known that the voltage  $v_{R1} = 4 \text{ V}$  and the current  $i_{R4} = 8 \text{ mA}$ . Use KCL, KVL, and Ohm's Law to find determine the value of  $I_S$ .

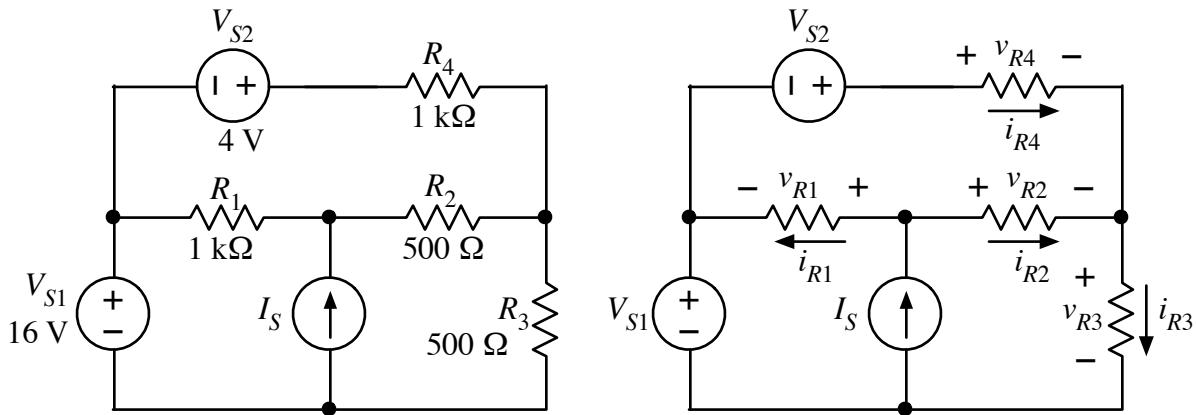

Also, calculate the power delivered by the sources and the power dissipated in each resistor. Show that the powers balance. (i.e. All of the power from the source is dissipated in the resistors.)

$I_S =$  \_\_\_\_\_ ;  $P_{R1} =$  \_\_\_\_\_ ;  $P_{R2} =$  \_\_\_\_\_ ;  $P_{R3} =$  \_\_\_\_\_

$P_{R4} =$  \_\_\_\_\_ ;  $P_{VS1} =$  \_\_\_\_\_ ;  $P_{VS2} =$  \_\_\_\_\_ ;  $P_{IS} =$  \_\_\_\_\_