

In the op-amp circuit shown, the source at the input changes abruptly from 0.5 V to 1.5 V at $t = 0$. Find the expression that describes the transient at the output, $v_o(t)$. The op amp is ideal.

Hint — start by considering how the circuit would behave if there were no capacitor. This gives you some idea of what to expect.

Another hint — focus on the capacitor voltage. Come up with a differential equation that relates v_C and v_S . Try to write it in the same form as equation on slide 4 of the RC transient notes and solve it similarly. Then relate v_o to v_C and v_S .

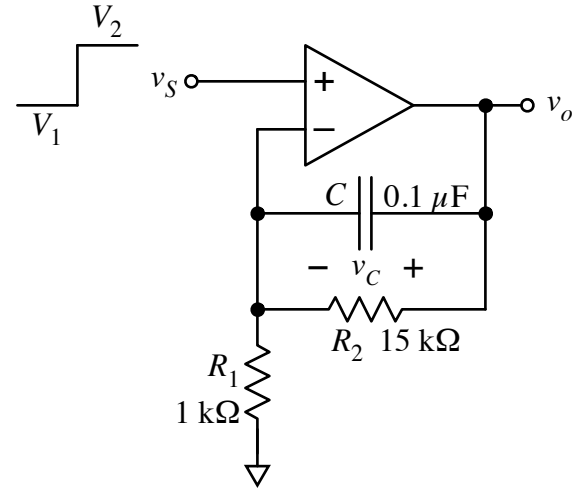

$v_o(t) =$ _____