

The oscillator circuit at right consists of a non-inverting amp with an *RLC* tank circuit.

Determine the loop gain function for the circuit.

Use the loop gain function to determine the expected frequency of oscillation and the minimum required gain for the amp to induce oscillation.

Calculate values for the oscillation frequency and minimum gain (i.e. minimum value of R_2/R_1) if $R_T = 1 \text{ k}\Omega$, $L = 1 \text{ mH}$, and $C = 1 \mu\text{F}$.

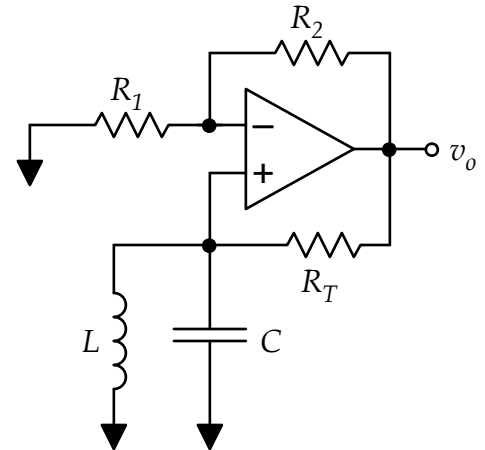

$\omega_o =$ _____ ; $R_2 / R_1(\text{min}) =$ _____